

Comm 469 Radio Reference

Cupertino 469
Cupertino Office of Emergency Service

14 July 2021

Cupertino ARES/RACES
10300 Torre Avenue
Cupertino, CA 95014-3255

Table of Contents

1	CONTACT INFORMATION	3
2	OPERATING FREQUENCIES	3
3	RADIO OPERATIONS.....	4
4	RADIO / ANTENNA CONNECTOR REFERENCE	7
5	RADIO ISOLATION PANEL.....	8
6	KENWOOD TM V71 144/440 DUAL BAND	10
7	KENWOOD TM-V71 ADVANCED SETTINGS	12
8	ALINCO DR-235T, PACKET	14
9	MOTOROLA CDM 1250 LOW BAND, EOC-TO-EOC	16
10	KENWOOD TK-8180 UHF, CITY TRUNK.....	18
11	KENWOOD TK-2140 UHF, CITY TRUNK, HT	19
12	MIDLAND MXT400 GMRS.....	19

210714.2051

Notes

11 Kenwood TK-2140 UHF, City Trunk, HT

This section covers the Kenwood TK-2140 UHF HT radio and specific operational setup steps. These radios are located Over Position 2 in the designated radio storage box. This radio is configured on the City of Cupertino Trunk Radio System.

FCC: Call sign: WQNG356; FRN: 0001537646

Licensee: Cupertino, City of

Radio Service: YW - Public Safety Pool, Trunked

Power Level: FB=60, MO=25, HT=5

Frequencies: 482.5625, 484.3500, 485.5625, 487.3500 MHz

1. Power-on Sequence

1. Turn on the radio with the **Power/Volume** knob (top right).
2. Select the Channel / Talk Group using center knob
3. To Talk, press PTT and **wait** for the Trunk Tone. On hearing it, speak into the microphone. Release PTT when done.

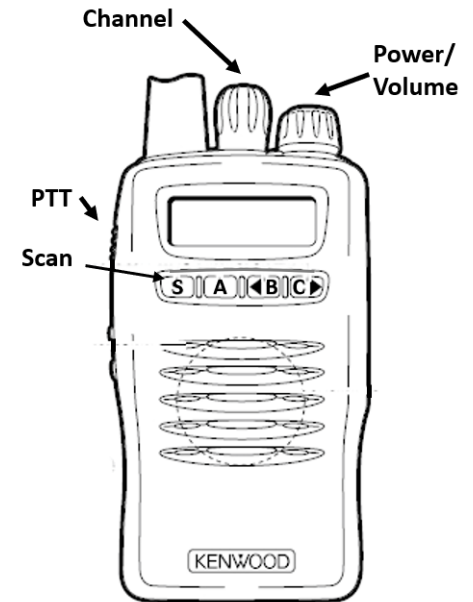

2. Operations

8. Our Operational Call is **OES-##**. Where ### is the number of this radio. Do not use your FCC Amateur Radio Call sign.
9. During normal operations, set the Talk Group to **PRIMARY**.
10. When we are deployed with field, set the Talk Group to **EOC** or whatever channel the Shift Supervisor tells you to use.

12 Midland MXT400 GMRS

Refer to the CERT Field Communications Handbook for a description of this radio and the channels assigned for Cupertino Citizen Corps use.

10 Kenwood TK-8180 UHF, City Trunk

This section covers the Kenwood TK-8180 UHF radio and specific operational setup steps. This radio is located in the Supervisors Radio Stack. This radio is configured on the City of Cupertino Trunk Radio System.

FCC: Call sign: WQNG356; FRN: 0001537646

Licensee: Cupertino, City of



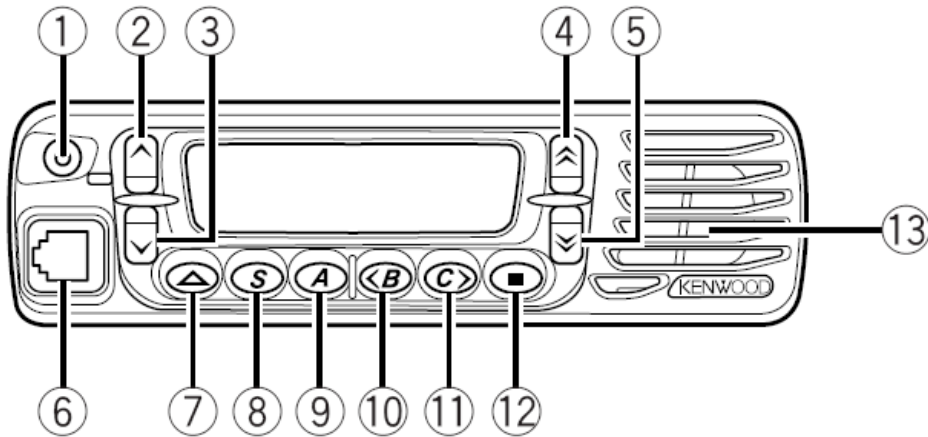

Radio Service: YW - Public Safety Pool, Trunked

Power Level: FB=60, MO=25, HT=5

Frequencies: 482.5625, 484.3500, 485.5625, 487.3500 MHz



1. Power-on Sequence

1. Turn on the radio by pressing the **Power** button (1, top left).
2. Adjust the **Volume** using the Up  (2) or down  (3) buttons.
3. Select the Talk Group using the Up  (4) or down  (5) buttons.
4. To Talk, press PTT and wait for the Trunk Tone. On hearing it, speak into the microphone. Release PTT when done.

2. Operations

5. Our Tactical Call is **COMM-469**. Do not use your FCC Amateur Radio Call sign.
6. During normal operations, set the Talk Group to **PRIMARY**.
7. when we are deployed with field units with City HTs, set the Talk Group to **EOC**.

1 Contact Information

Fire, Ambulance, other Emergency (9-1-1 alternate)	408-299-3233
Cupertino Service Center	
Main Office	408-777-3170
After hours, non-emergency	408-299-2311
After hours, Emergency	408-299-2507
Cupertino City Office	408-777-3200
Citizens Corp Coordinator	408-215-8459
CARES Emergency Coordinator	408-839-8798
CARES AEC, Training	408-533-2517
CARES AEC, Membership	408-813-4168
CARES AEC, PSC Vehicle Manager.....	408-761-3647
Santa Clara County Radio Room	408-808-7887

2 Operating Frequencies

CARES Frequencies

CH 1, Tac1, Resource Net	147.570	Tone = 151.4 simplex
CH 2, Tac2, Message Net	146.460	Tone = 151.4 simplex
CH 3, Res1, Resource Net	440.150 +	Tone = 100.0 W6TDM
CH 4, Res2, Resource Net	440.150	Tone = 100.0 simplex
CH 5, Tac5, Tactical, XBand	441.000	Tone,TSQL =151.4 Simplx
CH 6, Tac6, Tactical	147.585	Tone = 151.4 simplex
CH 7, Cmd1, Command	442.000 +	Tone = 151.4 WW6HP
CH 8, Cmd2, Command	442.000	Tone = 151.4 simplex
CH 11, Tac11, Tactical	147.570	Tone,TSQL =151.4 Simplx

County Frequencies

CH 21, SCC Message Net	147.360 +	Tone = 110.9 W6TI
CH 22, SCC Message Alt 1	145.450 -	Tone = 100.0 K6FB
CH 23, SCC Command	442.500 +	Tone = 100.0 WB6ZVW
CH 24, SCC Command Alt	443.275 +	Tone = 107.2 K6SNY
CH 25, SCC Resource Net	146.115 +	Tone = 100.0 AA6BT
CH 26, SCC Resource North	145.270 -	Tone = 100.0 W6ASH
CH 27, SCC Resource South	444.625 +	Tone = 110.9 N6NAC
CH 28, SCC Hospital Net	145.230 -	Tone = 100.0 N6NFI
CH 29, NTS Net	146.640 -	Tone = 162.2 WR6ABD

Packet Frequencies

SCC Office Bldg (San Jose)	145.750, 223.620, W1XSC-1	(CUP Pri)
Crystal Peak (South County)	145.730, 223.560, W2XSC-1	
Mountain View	144.310, 223.540, W3XSC-1	
Frazier Peal (Above Milpitas)	145.690, 223.600, W4XSC-1	(CUP Sec)

Emergency Alert System, stations of interest

KCBS	740 KHz	LP1, National Primary EAS Station
KFBK	1530 KHz	CA State Primary EAS Station
KLIV	1590 KHz	Public AM Station, a CNN affiliate
WQGH344	1670 KHz	Cupertino Community Radio

3 Radio Operations

The three main radio operating positions are outfitted with a Kenwood TM-V71 radios and a kit with the necessary operating accessories.

1. The radio bodies are located in the equipment rack.
2. The radio “control heads” are situated in front of each operating position.
3. Three cables connect each radio to the operating positions:
 1. Head Extender cable
 2. Push to Talk cable
 3. Two channel audio cable
4. These cables terminate at the Radio Interface. See the following section for details.
5. A remote single channel speaker is located at each position; it can be switched to listen to either the left or right side of the radio.
6. Either a (i) hand Mic and speaker or (ii) headset with PTT foot peddle can be used. See the following sections for details.

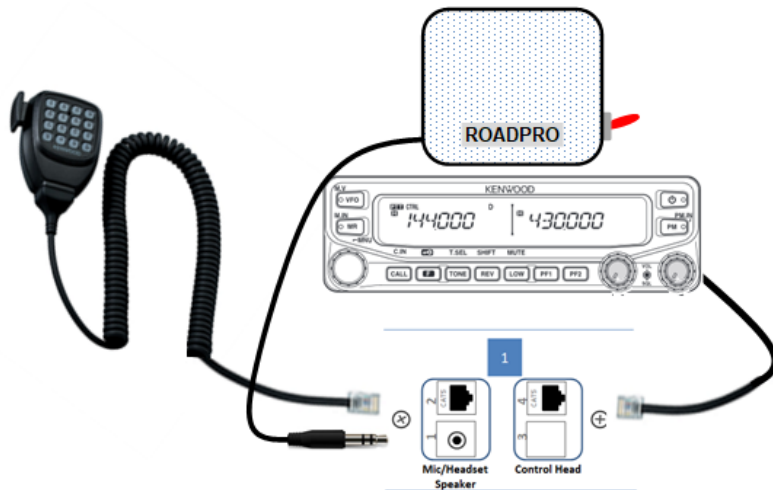

3. Ring-down Codes

EOC Location	Designation	Ring down
County Comm Ctr	COM	*266
OpArea EOC	OES	*637
Campbell	CMB	*262
Cupertino	CPT	*278
Cupertino Alt	CPO	*276
Gilroy	GLR	*457
Lockheed Martin	LMC	*562
Los Altos	CLA	*252
Los Altos Hills	LAH	*524
Los Gatos/Monte Sereno	LGT	*548
Los Gatos Alternate	MTS	*687
Milpitas	MLP	*657
Morgan Hill	MHL	*645
Mountain View	MTV	*688
Mountain View Alt		
NASA/AMES	NAM	*626
Palo Alto	CPA	*272
San Jose	CSJ	*275
Santa Clara	SCL	*725
Saratoga	SRG	*774
Sunnyvale	SNV	*768
SCV Water Dist.	VWD	*893
Silicon Valley Red Cross	SCV	728
SJ State Univ.	SJS	*757
Stanford University	SUF	*783
Radio All Call	N/A	####

9 Motorola CDM 1250 Low Band, EOC-to-EOC

This section covers the Motorola CDM 1250 Low Band radio and specific operational setup steps. This radio is located in the Supervisors Radio Stack.

FCC: Call sign: WPDD896; FRN: 0001539824

Licensee: Santa Clara, County of

Radio Service: PW - Public Safety Pool, Conventional

Power Level: 40-60W

Frequencies: TX=37.960 MHz, RX=37.080 MHz, PL=85.4

Programming: 1. EOC-to-EOC System Repeater

2. EOC-to-EOC Repeater Output (simplex)

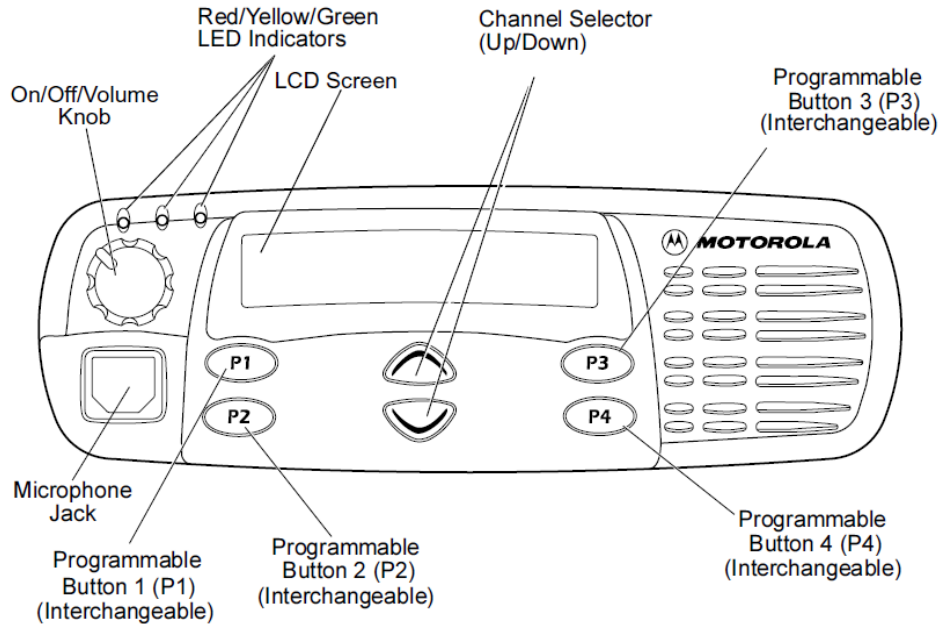

1. Power-on Sequence

1. Turn on the radio by pressing the **On/Off/Volume** Knob, upper LEFT. If Successful, you will hear a Self-test "tone, two. If Unsuccessful, you will hear a Self-test tone, one.
2. Adjust the volume using the **On/Off/Volume** Knob.
3. Select the EOC Repeater. Use the Channel Selector (up or down) to make your selecting. Use the Hand microphone to key the radio. Note the repeater squelch tail. No tone is issued.

2. Operations

4. Our Tactical Call is **CUPERTINO EOC**. Do not use your FCC Amateur Radio Call sign on this radio.

Radio Interface

The Radio Interface links all operator controls with the radio body. Each Interface has houses three connectors that are specific to the radio; they cannot be used as a VANnet network connection. These connectors are:

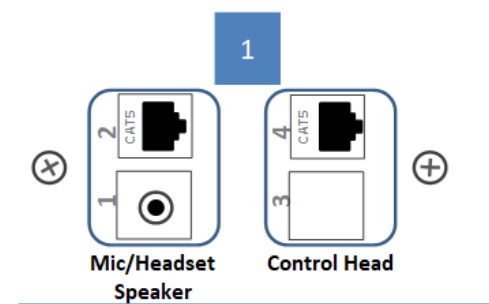

1. **Mic/Headset, Top Left;** connects either a hand Mic or the headset adaptor.
2. **Radio Speaker, Bottom Left;** connects either the local speaker or the headphone cable. These connectors can be identified by the **double black rings** on the connector barrel (see picture below).
3. **Radio Control Head, Top Right;** connects the radio head. DO NOT insert any other network device into this connector. This cable should always be connected. **DO NOT REMOVE.**

Operating with a Microphone

To operate with a microphone, do the following:

1. Retrieve the microphone for this operating position.
2. Plug the microphone into the Radio Interface, **top left**.
3. Plug the radio speaker into the Radio Interface, **lower left**.
4. Speaker operations are either Left or Right Channel at a time. Use the speaker switch to select either channel.
5. Verify normal radio operations.

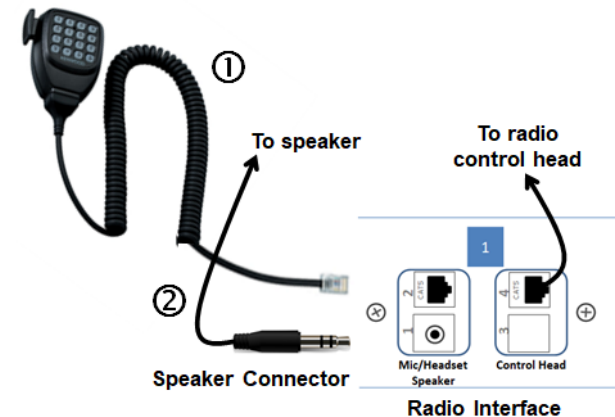

Operating with a Headset

To operate with a Headset, do the following:

- _____ 1. Retrieve the following components for this operating position.
 - Heil Headset ①
 - Headset adaptor ②
 - PTT Footswitch ③

- _____ 2. Plug the headset microphone jack (**single black ring** on the connector barrel) into the Headset Adaptor.
- _____ 3. Plug the Foot Switch jack (larger ¼" connector) into the Headset Adaptor.
- _____ 4. Plug the Headset Adaptor into the Radio Interface, **top left**.
- _____ 5. Plug the headset earphone jack (double black rings on the connector barrel) into the Radio Interface, **lower left**.
- _____ 6. Set the radio volume and squelch controls for comfortable listening.
- _____ 7. Verify normal radio operations.

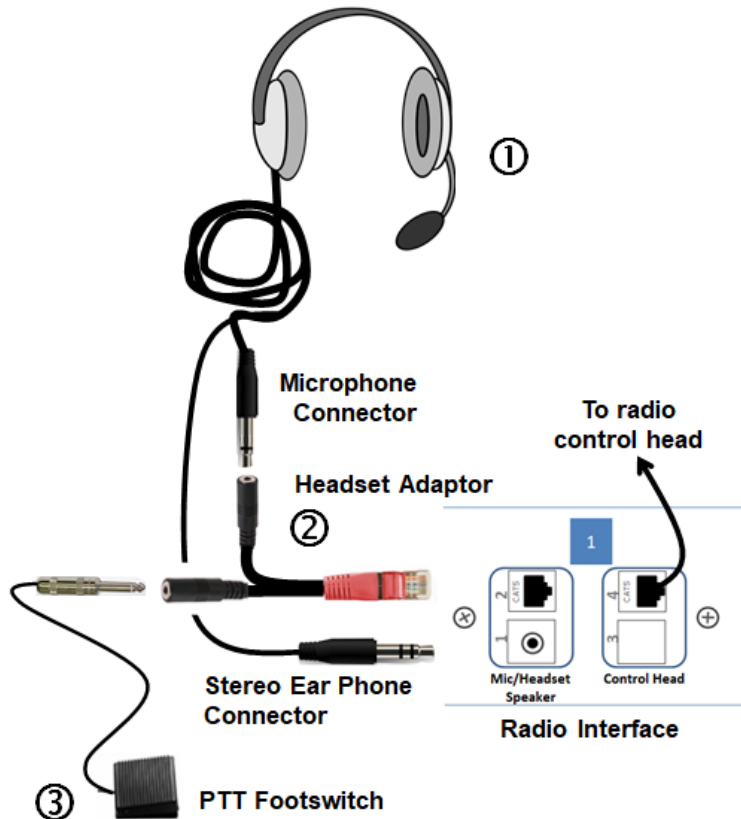

4. TNC Power

- _____ 11. The TNC should power on with the equipment rack. Visually confirm the power-on indicated lights. If it is not on, press the ON button on the TNC.

5. Computer Power On

The PC is mounted under the Packet workstation.

- _____ 12. Press the ON button on the Packet PC. Log into the PC: Password is _____
- _____ 13. Find the **Outpost SCC** icon and double-click on it. Verify the **Outpost** Program starts up.
- _____ 14. When prompted, select or set up your Call Sign. Enter all fields.
- _____ 15. Select the menu options and confirm or set the following:

Setup > Identification	Enter your Call Sign in the User Call Sign field. Enter your first and last name in the User Name field. Check the "Use Tactical Call..." box. Set the Tactical Call Sign to CUPEOC . Set the Tactical ID to CUP . Press OK when done.
Setup > BBS	Verify the BBS Name is W1XSC-1 . Press OK when done.
Setup > TNC	Tab 1: Interface Type: Verify Device Name is KPC-3 and Device Type is TNC . Tab 4: TNC Comm Port: Verify settings: Comm Port= ____, Baud=9600, Data Bits=8, Parity=None, Stop Bits=1. Press OK when done.

Connect check

- _____ 16. From Outpost, Press Send/Receive button, top right. Verify the Session Manager Form opens, Outpost connects to the BBS, and retrieves any messages, and closes.

8 Alinco DR-235T, Packet

This section covers the Alinco DR-235T radio used for Packet radio and the specific operational setup steps. Button reference numbers are listed in (parenthesis).

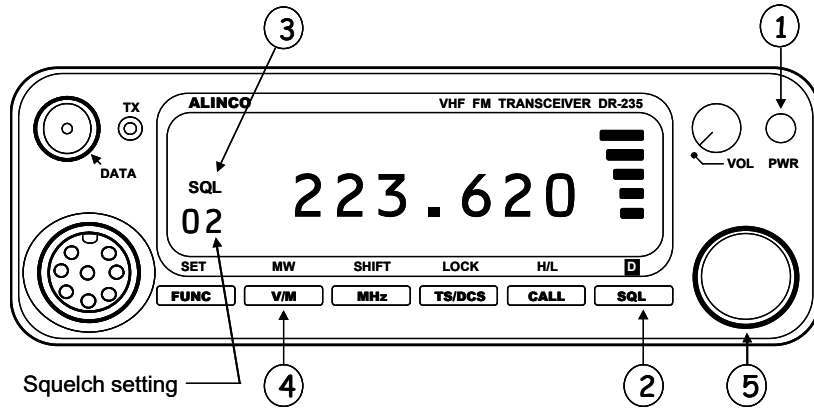

1. Power-on Sequence

- ___ 1. Turn the radio on by pressing the **PWR** button (1)
- ___ 2. Set the Squelch by pressing the **SQL** key (2). The **SQL** (3) icon appears on the display and the squelch level will be shown. Set the Squelch level to 2. After 5 seconds, the display returns to normal.
- ___ 3. Set the Volume level to so that the indicator is in the 10 o'clock position.
- ___ 4. Select Memory Mode by depressing the **V/M** key (4). Verify that the **M** icon appears on the display.
- ___ 5. Rotate the **MAIN** Dial (5) to select the frequency: 223.620 MHz.
- ___ 6. Verify the TNC-to-PC cable is connected.
- ___ 7. Press **PWR** (1) to turn off.

2. Change Power Level

- ___ 8. Press **[FUNC]** (bottom left) and then **[H/L]** to toggle the transmit output power.

3. Change Frequency

- ___ 9. Press the **V/M** key (4). Verify that the **V** icon appears on the display.
- ___ 10. Rotate the **MAIN** Dial (5) to select the frequency. Press the **MHz** key for courser or finer frequency tuning.

4 Radio / Antenna Connector Reference

Antenna Numbering

No	Type	Normal Use	Location
A1	2M/440	R2 – County Message Net	Roof
A2	37.00 MHz	R7 - EOC	Roof
A3	Multi-band	R8 – Public Safety	Roof
A4	2M/440	Spare	Roof
A5	480 MHz	R6 - City Trunk	Roof
A6	2M/440	R4 – Shift Supervisor	Mast
A7	220 MHz	R5 - Packet	Mast
A8	2M/440	R1 – Resource Net	Mast
A9	2M/440	R3 – City Mess Net	Mast

Radio Numbering

No	Type	Position	Normal Antenna
R1	Kenwood TM-71A	Resource Net	A8
R2	Kenwood TM-71A	County Message Net	A1
R3	Kenwood TM-71A	City Message Net	A9
R4	Kenwood TM-71A	Shift Supervisor	A6
R5	Alinco DR235 - Packet	Shift Supervisor	A7
R6	Kenwood TK8180 – City	Shift Supervisor	A5
R7	CDM1250 – EOC	Shift Supervisor	A2
R8	Scanner	Shift Supervisor	A3
B1	BSP Connector 1		
B2	BSP Connector 2		
C1	Cab Connector 1		A4
C2	Cab Connector 2		

Antenna Numbering, Roof View

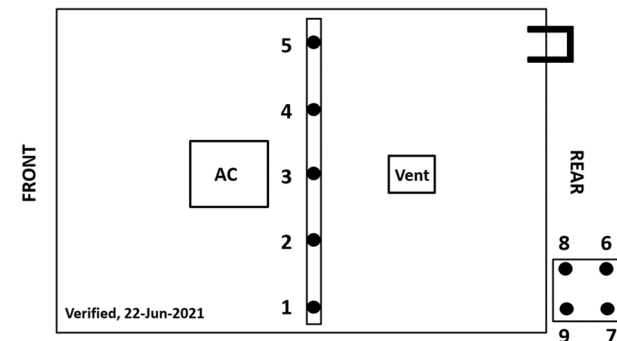

5 Radio Isolation Panel

Introduction

The “VHF Filter Isolation Panel” is used to ensure the CARES TAC1 and TAC2 frequencies are sufficiently isolated so that communications can occur simultaneously on both channels.

Specifically, this panel addresses the problem where a Comm 469 operator is transmitting on TAC1 while a field resource is transmitting on TAC2. Because the TAC2 radio receiver is saturated by the TAC1 transmission, the TAC1 field transmission is never received. The same occurs when the situation is reversed.

The set up for normal CARES operations is:

1. Operating position 1. CARES resource net on TAC1 147.570
2. Operating position 3. City message net on TAC2 146.460

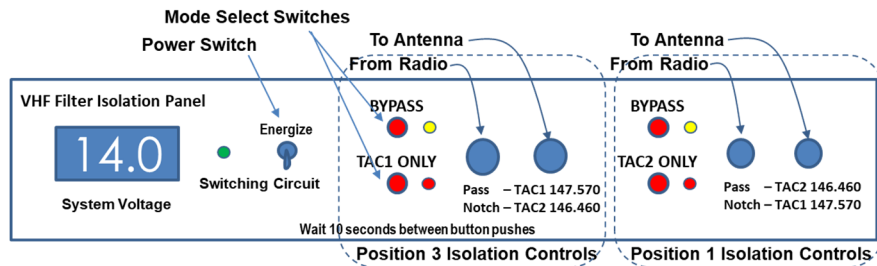

Set up for normal CARES operations

1. Set the radio at Position 1 to CARES resource net, TAC1, 147.570.
 2. Set the radio at Position 3 to CARES message net, TAC2, 146.460.
 3. On the Isolation Panel, verify the TAC1 ONLY LED is lit.
 4. On the Isolation Panel, verify the TAC2 ONLY LED is lit.
- If either are in BYPASS Mode, do the following:
5. Energize the Isolation Panel (switch to the right of the volt meter).
 6. If TAC1 shows it is in BYPASS mode, press the RED button marked TAC1 ONLY to enable Isolation on TAC1.
 7. If TAC2 shows it is in BYPASS mode, press the RED button marked TAC2 ONLY to enable Isolation on TAC2.
 8. Deenergize the Isolation Panel.

NOTE: Wait at least 10 seconds before toggling between the positions' BYPASS and TACx ONLY choices.

Radio Reset

There are the 4 types of transceiver reset available:

VFO Reset:	Use to initialize the VFO and accompanying settings.
PART (Partial) Reset:	Use to initialize all settings other than the Memory channels, the DTMF memory, and the PM channels.
PM Reset:	Use to reset only the Programmable Memory channels to their default values.
FULL Reset:	Use to initialize all transceiver settings that you have customized.

Note: Unless otherwise directed, only perform a **VFO** or **PART Reset** on the radios. All other reset options will require a frequency reload.

Perform a reset on the transceiver by key operation:

10. Turn the transceiver off.
11. Press **[F] + Power On**
12. Rotate the Tuning control and select your desired reset type: VFO, PART, PM, or FULL.
13. Press the Tuning control to set the reset type.
14. To Cancel: Press **[TONE]** (BACK) to return to the previous display or **[F]** (ESC) to cancel the reset.
15. Press the Tuning control again to perform the reset.

7 Kenwood TM-V71 Advanced Settings

Cross-Band Operations

To set up Cross-Band operations, do the following:

- _____ 1. Set the left Channel with the desired 2-meter frequency, and the right channel with the desired 440 frequency.
- _____ 2. Enter Menu Mode
Press **[F]**, **Tuning** control to access the Menu.
- _____ 3. Enable Repeater Option to Cross Band
 1. Rotate the **Tuning** control to select **Menu 403 (RPT.MOD)**.
 2. Press the **Tuning** control to select this menu.
 3. Rotate the **Tuning** control to select operating mode CROSS.
 4. Press the **Tuning** control to deselect this menu.
- _____ 4. Enable Repeater Hold

Optional: You can set the transceiver to remain in transmit mode for 500ms (1/2 second) after the signal drops. To use this feature,

 1. Rotate the **Tuning** control to select **Menu 404 (RPT.HLD)**.
 2. Press the **Tuning** control to select this menu.
 3. Rotate the **Tuning** control to select ON or OFF.
 4. Press the **Tuning** control to deselect this menu.
- _____ 5. Enable transmit a Repeater ID

Recommended: Set up your radio to transmit your ID every 10 minutes. Set this up as follows:

 1. Rotate the **Tuning** control to select **Menu 406 (ID.TX)**.
 2. Press the **Tuning** control to select this menu.
 3. Rotate the **Tuning** control to select MORSE (CARES does not have the voice module is not installed in our radios).
 4. Press the **Tuning** control to deselect this menu.
- _____ 6. Enter the Repeater ID

If you enabled Repeater ID above, then set the call sign you wish to transmit as follows:

 1. Rotate the **Tuning** control to select **Menu 405 (RPT.ID)**.
 2. Press the **Tuning** control to select this menu. The first character position will blink.
 3. Rotate the **Tuning** control to enter the desired character.
 4. Press the **Tuning** control to move to the next character position. The next character position will blink.
 5. Repeat steps 4d and 4e for all other character positions.
 6. Press the **Tuning** control to deselect this menu.
- _____ 7. Exit Menu Mode
Press **[F]**, **(ESC)** at any time to exit Menu Mode.
- _____ 8. Turn off the Radio. Then, press the **[Tone]** and the **Power** button (**14**) at the same time. The radio is now in Cross-Band.
- _____ 9. Repeat the above step to turn off Cross-Band Operations.

Set up for non-CARES operations

- _____ 9. Set the radio at Position 1 to the desired frequency.
- _____ 10. Set the radio at Position 3 to the desired frequency.
- _____ 11. Energize the Isolation Panel (switch to the right of the volt meter).
- _____ 12. If Position 1 needs to be in BYPASS mode, Press the RED button marked BYPASS above the TAC2 ONLY label to enable Bypass on the Position 1 radio.
- _____ 13. If Position 3 needs to be in BYPASS mode, Press the RED button marked BYPASS above the TAC1 ONLY label to enable Bypass on the Position 3 radio.
- _____ 14. Deenergize the Isolation Panel.

6 Kenwood TM V71 144/440 Dual Band

This section covers the Kenwood TM V71 144/440 Dual Band radio and specific operational setup steps. Button reference numbers are listed in (parenthesis). See *Section 2, Operating Frequencies* for channel assignments.

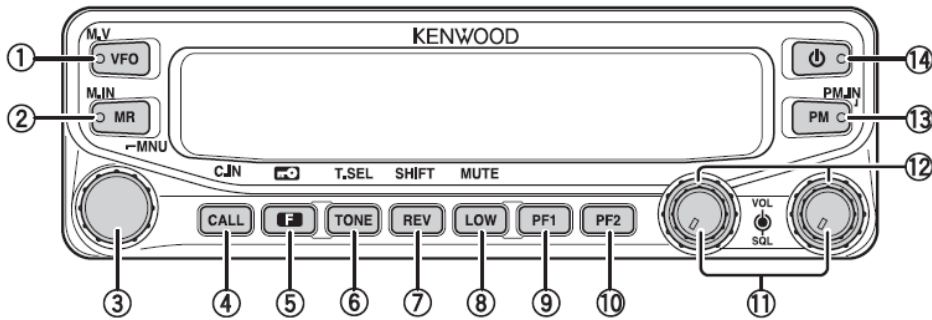

1. Power-on Sequence

15. Turn on the radio by pressing the **Power** button (14, top right).
16. Make sure the radio is in a known state, first by pressing **[VFO]** (1).
17. Then, select Memory Mode by pressing **[MR]** (2).
18. Adjust the **Squelch** (12, right knobs, outer ring).
19. Adjust the **Volume** (11, right knobs, inner ring).
20. Select the LEFT band for transmit by PRESSING the left **BAND** button (11-left).
21. Select the desired 2-meter frequency with the **Tuning** knob (3). Refer to Page 2 for the list of frequencies.
22. Select the RIGHT band for transmit by PRESSING the right **BAND** button (11-right).
23. Microphone operation is as usual.

Note: The Kenwood TM-V71 is a very flexible and configurable radio and allows you to set up your frequencies in the Left and Right channels any way you wish. While this document presents the VHF frequencies in the Left Channel and the UHF frequencies in the Right Channel,

2. Change Power Level

24. Press **[LOW]** (8) to toggle the transmit output power as follows:
High Power → Middle Power → Low Power →...

3. Storing a Frequency to Memory

25. Press **[VFO]** (1) to select **VFO** mode.
26. Select the 2-meter band by PRESSING the left **BAND** button (11) or the 440 band by PRESSING the right **BAND** button (11).
27. Enter the frequency by using the **Tuning** control (3). Press the **Tuning** control to select the **MHz** digit, press it again to select **KHz** digit.
28. For Repeaters, set the Offset Direction. Press the **[F]** then **[SHIFT]** button (see the next menu set after **[F]** is pressed). The selection is advanced from “**Simplex**” to “+” to “-”, and then “**Simplex**”. Press any blank menu key or button to accept the change.
29. For Repeaters, turn Tone on. Press **[Tone]** (7). Repeat pressing **[Tone]** until **T** (Tone) is displayed on the menu (left of “**FM**”).
30. Select the Tone Frequency. Press **[F]** then **[T.SEL]** buttons (see the next menu set after **[F]** is pressed). Turn the **Tuning** control until the desired tone is selected. Press any blank menu key or button to accept the change.
31. Store the Frequency. Press the **[F]** menu button, a memory channel number appears and flashes below the “**FM**” display and above the frequency last digit. Select an empty memory location by turning the **Tuning** Control. Press the **[M.IN]** (2) button to store the frequency.
32. Verify memory channel entry. Select Memory Mode **[MR]** (2). The display should show the entered frequency and offset.

4. Clear a Memory Channel

33. Press **[MR]** (2) to select **Memory** mode. Tune to the memory location to be deleted.
34. Turn off the Radio (14)
35. Press **[MR]** (2) and **Power** button (14) at the same time.
36. A confirmation message will appear on the display: **CLEAR?**
Press the Tuning control (3) to clear the Memory channel
Press **[F](ESC)** to cancel the operation.